

CP-32A SINKER DRILLS

EDITION, DECEMBER 2003

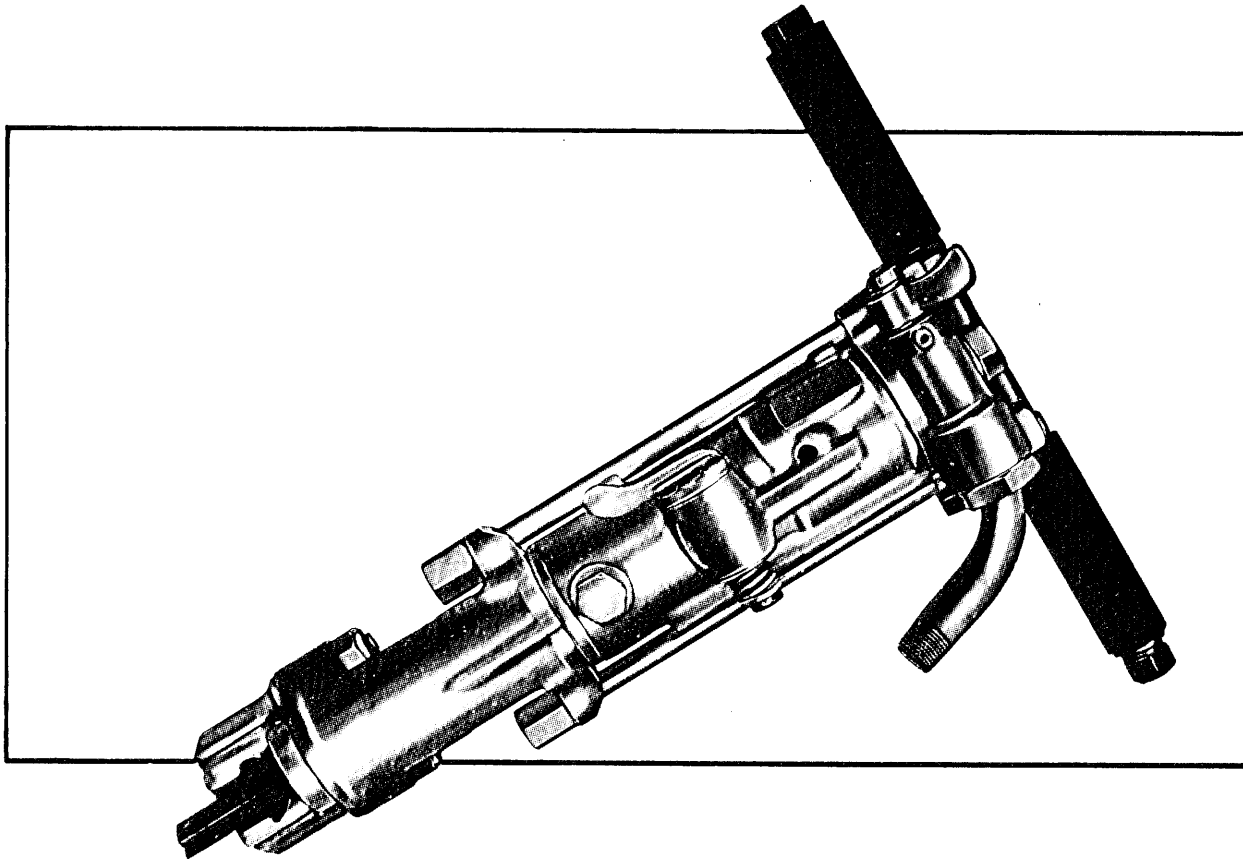

Instruction and Parts Book for

SINKER DRILLS

CP - 32A Model "L"



**Chicago
Pneumatic™**

Chicago Pneumatic Construction Tools, SE-105 23, Stockholm, Sweden.
www.chicagopneumatic.com

R 278158

CP0032A SINKER DRILL Model "L"

All Threads Are Right Hand
Unless Otherwise Specified

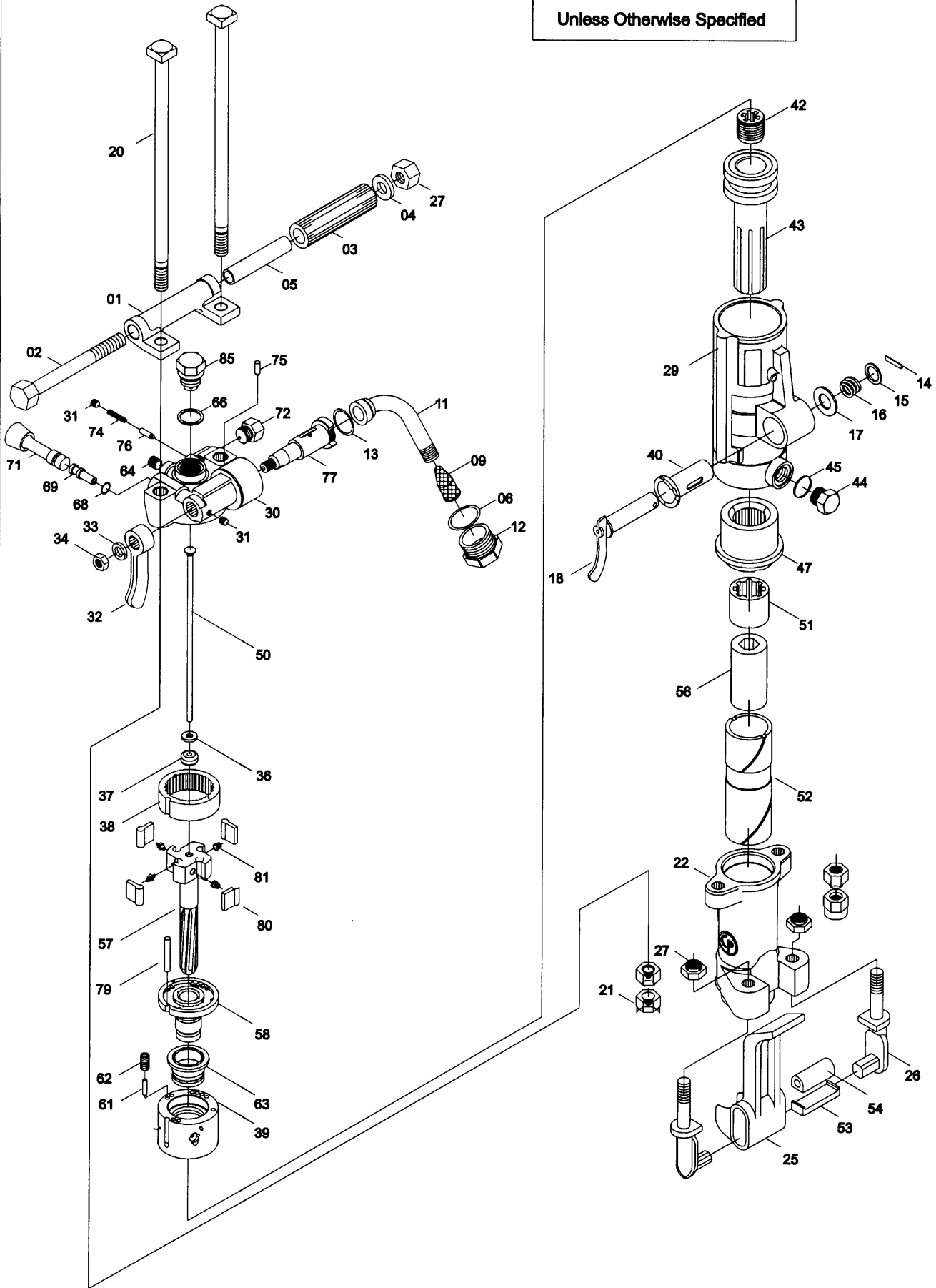

CP0032A SINKER DRILL Model "L"

ROCK DRILL 619

INDEX NO	CP PART NO	DESCRIPTION	NO. Req'd	INDEX NO	CP PART NO	DESCRIPTION	NO. Req'd
1	R086608	Bracket - Handle	1	50	R077184	Tube - Air	1
2	R076173	Bolt - Handle	1	51	R086733	Nut - Chuck Rotation	1
3	R075419	Grip - Handle	2	52	R041321	Sleeve - Chuck (7/8" x 3-1/4")	1
4	R000142	Washer - Handle Bolt Key	1		R041324	Sleeve - Chuck (7/8" x 4-1/4" & 1" x 4-1/4")	
5	R076172	Liner - Handle	1	53	R093898	Retainer - Latch Shoe	1
6	R110317	"O" Ring (.976 I.D.)	1	54	R093897	Buffer - retainer	1
9	R005584	Screen - Air Inlet	1	56	R099374	Chuck (7/8" Hex. x 3-1/4")	1
11	R075265	Swivel - Air Inlet	1		R093891	Chuck (7/8" Hex. x 4-1/4")	1
12	R000530	Nut - Air Inlet Swivel	1		R093890	Chuck (1" Hex. x 4-1/4")	1
13	P103521	"O" Ring (-128)	1	57	R086622	Bar - Rifle	1
14	R076266	Pin - Spring	1	58	R076263	Valve	1
15	R075780	Washer - Valve Spring	1	61	R085625	Stem - Oil Regulating	1
16	R075778	Spring - Blower Valve	1	62	R098084	Plug - Oil Regulating	1
17	R075777	Washer - Blower Valve	1	63	R098085	Bushing - Valve Guide	1
18	R086612	Valve - Blower	1	64	C068799	Plug - Pipe (1/4")	1
20	R086623	Bolt - Thru	2	65	R076793	Plug - Air Tube	1
21	R085756	Nut - Thru Bolt	2	66	R000537	Gasket - Tube Plug	2
22	R041320	Fronthead (7/8" Hex x 3 1/4")	1	68	C079489	"O" Ring	1
	R041323	Fronthead (7/8" x 4-1/4" & 1" x 4-1/4")		69	R098054	Bushing - Water Valve	1
25	R093913	Retainer (7/8" Hex.)	1	71	R079130	Water Valve Port Plug	1
	R093895	Retainer (1" Hex.)	1			Complete (Incl: Index No. 68)	
26	R093898	Trunnion - Retainer	2	72	R076372	Plug - Water Valve	1
27	R005742	Nut - Elastic Stop (5/8" - 11)	3	74	R085671	Spring - Valve Plunger	1
29	R087990	Cylinder (Incl: Index No. 40)	1	75	R075802	Pin - Valve Plunger	1
30	R087848	Backhead (Incl: Index No. 60)	1	76	R086627	Plunger - Throttle Valve	1
31	C068064	Plug - Pipe (1/8")	2	77	R086628	Valve - Throttle	1
32	R079124	Handle - Throttle Valve	1	79	R075772	Pin - Valve Case Dowel	1
33	C036717	Lock Washer - Viv Handle (1/2")	1	80	R075267	Pawl	4
34	P002149	Nut - Hex. (Thin 1/2" -20)	1	81	R086654	Spring - Pawl	4
36	R075449	Washer - Air Tube	1	82	R154915	Vib Handle Kit	1
37	R075099	Rubber - Air Tube	1			(Incl: Index No. 83,84)	
38	R076194	Ring - Ratchet	1	83	R157932	Hex. Nut - Thin	2
39	R076264	Case - Valve	1	84	R157933	Rod - Threaded	1
40	R086611	Bushing - Blower Valve	1				
42	R075839	Nut - Rifle Bar (Steel)	1				
	R075826	Nut - Rifle Bar (Bronze)					
43	R000088	Piston	1				
44	R085611	Plug - Oil (Incl: Index No. 45)	1				
45	R091176	Gasket - Oil Plug	1				
47	R042161	Bushing - Cylinder	1				

Not
Shown

ACCESSORIES

1. R- 125569 MUFFLER ASSEMBLY

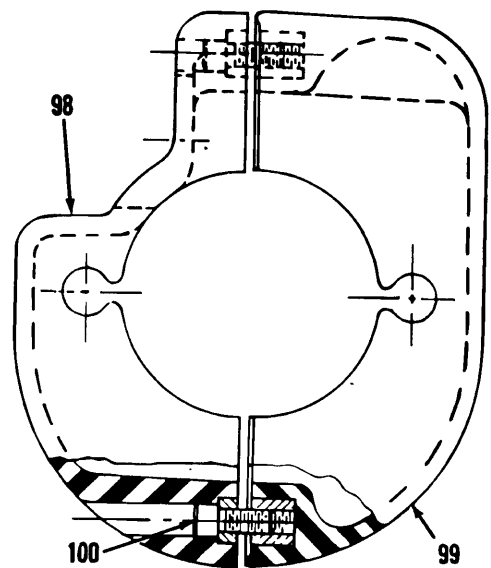
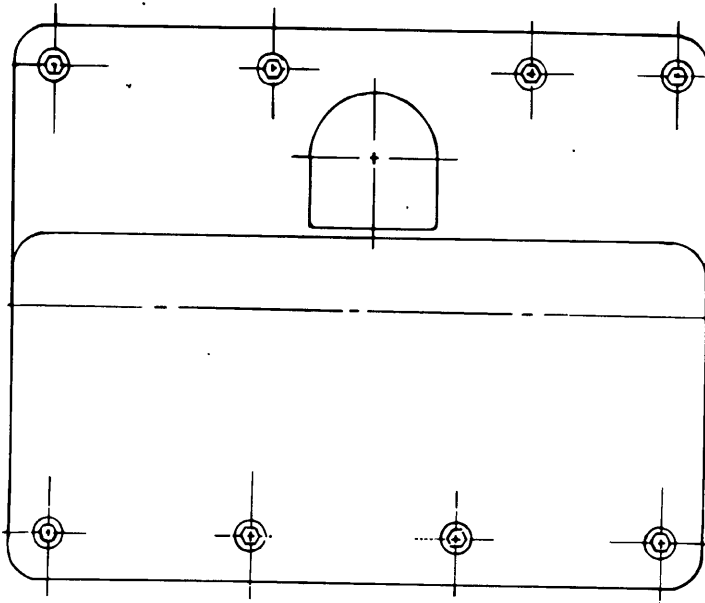
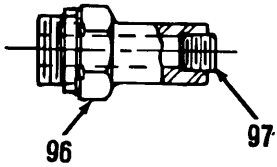

Index No.	CP Part No.	Description	
96	R124145	Cap - Filler (Incl Index No. 45)	1
97	C068799	Plug - Pipe	1
98	R124143	Hood-Muffler (Right)	1
99	R124144	Hood-Muffler (Left)	1
100	R117415	Screw (5/16 - 24 x 3/4)	8

2. WATER KIT

2.1 R-007688 WATER CONNECTION COMPLETE

(Includes all parts shown below except R-000538, R-005452, & R-000576)

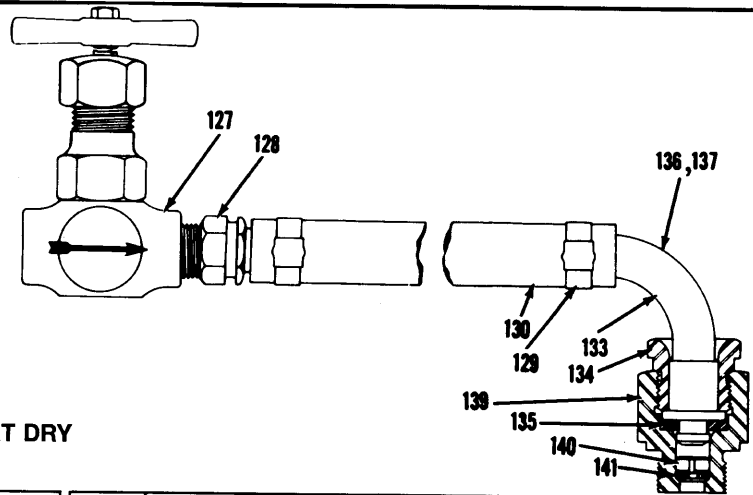

All Threads Are Right Hand Unless Otherwise Specified.

2.2 CONVERSION KITS

USE R147457 KIT WET & WTR CONTROL TO CONVERT DRY

(Includes All Parts in Following Table)

Index No.	CP Part No.	Description	No. Req'd.	Index No.	CP Part No.	Description	No. Req'd.
127	H073425	Valve-Water	1	136	R077708	Hose-Connection Complete (Incl: Index No's 128 Thru 135)	1
128	P002083	Nipple-Hose	1	137	R007688	Water-Connection Complete (Incl: Index No's 127 & 136)	1
129	C090672	Clamp-Punch Lok (1" ID X 5/8")	2	139	R000538	Spud-Water Inlet	1
130	R000790	Hose (1/2" X 12" Long)	1	140	R005452	Retainer-Water Strainer	1
133	R005432	Swivel-Water Inlet	1	141	R000576	Strainer -Water	1
134	R000788	Nut-Water Inlet Swivel	1				
135	R005451	Gasket-Swivel	1				

STD TERM & STD WATER CONTROL

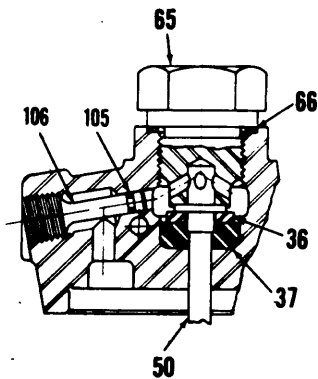

AUTOMATIC WATER CONTROL

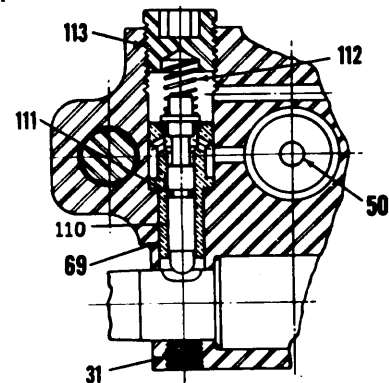

Remainder of parts shown on pages 2,3, & 4 Includes R007688 water connection with index No's. 139,140 & 141 shown above

Index No.	CP Part No.	Description	No. Req'd.	Index No.	CP Part No.	Description	No. Req'd.
36	R075449	Washer-Air Tube	1	31	C068064	Plug-Pipe(1/8")	1
37	R075099	Rubber-Air Tube	1	50	R092420	Tube-Water	1
50	R092420	Tube-Water	1	69	R098054	Bushing-Water Valve	1
65	R076793	Plug-Air Tube	1	110	R098053	Valve-Water	1
66	R000537	Gasket	1	111	C079489	"O" Ring(-008)	1
105	C087316	"O" Ring(-006)	1	112	P006758	Spiring-Water Valve	1
106	R085627	Plug-Blower Port	1	113	R085494	Plug-Spring Retainer	1

2.3 CONVERSIONS

To Convert From	To	Take Out	Put In
Blower Dry	To Plain Wet	- R-077184, C-068799, R-076372, R-000537	- R-085627, C-087316, R-000538, R-005452, R-092420, R-000576, R-007688
	To Automatic Water Control	- C-068799, R-077184, R-076372, R-000537, R-079130	- R-092420, R-085627, C-087316, R-077708, R-000538, R-005452, R-000576, R-098053, R-085494, P-006758
Plain Wet	To Blower Dry	- R-092420, R-007688, R-000538, R-005452, R-000576, R-085627, C-087316	- R-077184, R-000537, R-076372, C-068799
	To Automatic Water Control	- R-079130, H-073425	- R-098053, P-006758, R-085494
Auto Water Control	To Plain Wet	- R-098053, P-006758, R-085494	- R-079130, H-073425
	To Blower Dry	- R-085627, C-087316, R-092420, R-098053, P-006758, R-085494, R-077708, R-000538, R-005452, R-000576	- C-068799, R-076372, R-000537, R-077184, R-079130

When ordering spare parts, give Name, Speed or Size, Model and Serial Number of the tool and Part Number and Description of each part desired.

GENERAL INSTRUCTIONS

The modern Rock Drill is a high speed machine with a number of close-fitting, precision made parts, but is subject to a terrific amount of punishment. Therefore, it is highly important that your drill receive reasonable care, adequate lubrication at all times and regular inspections.

WARNING: "PROLONGED USE OF VIBRATING TOOLS BY CERTAIN USERS MAY BE HARMFUL TO HANDS AND ARMS."

Always wear approved safety footwear and eye protection to avoid personal injury.

CAUTION: When operating tool to flush out gum and foreign matter, direct the exhaust away from operator and co-workers.

Lubrication

As it comes from the factory, the inside of the tool is coated with heavy, rust inhibiting oil. After unpacking, pour a small amount of kerosene into air connection and operate tool on partial throttle to clean interior. Follow immediately with a liberal amount of light, rock drill oil. During operation the use of a one pint line oiler R051776 is recommended.

During operation keep oiler filled - a one pint oiler holds an average four hour supply, but if a high rate of feed is required by oil characteristics or the air consumption of the tool, more frequent filling will be necessary. At least twice a shift remove oil plug (44) and fill reservoir with recommended oil.

When properly lubricated, a mist of oil, enough to be visible on the bare hand, will be present in the exhaust air. A slight film of oil should be visible on the drill steel.

Proper lubrication is important. A few minutes operation without oil will wear out the rifle bar, rifle bar nut, chuck rotation nut and the pawls and will severely score the cylinder, cylinder bushing, valve and fronthead.

Recommended Lubricants

The use of synthetic oils is NOT RECOMMENDED due to possible damage to seals, "O" rings, hoses, blades and polycarbonate oiler/filter bowls.

Manufacturer	Below 40°F	40°F to 80°F	Above 80°F
CP	Airolene Tool Oil		
Esso	Arox EP45	Arox EP65	
Mobiloil	Velocite No.10	Almo No. 3	Almo No. 5
Texaco	Regal Oil B (R & O)	Regal Oil PE (R & O)	Regal Oil F (R & O)
Delton	Silkolene 773	Silkolene 548/T	Silkolene 881
Shell	Tonna R27	Tonna R41	Tonna R72
Burmeh Castrol	Megna SPX	Castrol RD Oil Light	Castrol RD Oil 3
BP Power Petroleum	RD80 HP10-C	RD160 HP20-C	RD220 HP60-C
Duckham	Zero Flo 5	Garnet 6	Garnet 7
Sternol	Merlin 54	Merlin 71	Merlin 87
Petrofina	Purifoc 32	Purifoc 46	Purifoc 53
Chevron	Vistac Oil 9X	Vistac Oil 19X	Vistac Oil 18X
Caltex	Caltex XL	Caltex XM	Caltex XH

Preparing for Operation

WARNING: "ALWAYS CHECK FOR DAMAGED OR LOOSE HOSES AND FITTINGS BEFORE OPERATION. WHIPPING HOSES CAN CAUSE SERIOUS INJURY."

Daily before placing drill in service blow out the air line to clear it of accumulated dirt and moisture. Check tool and make sure the air and water inlets and the exhaust ports are free from obstruction. Be sure the air strainer is clean and not torn or distorted.

Pour about one ounce of Rock Drill oil directly into the air inlet of the tool before connecting air hose to the tool.

Inspect drill steel shanks and make sure they are the correct size and length for the chuck used. Shanks which are chipped, rounded, out of square or too hard on the striking end will operate inefficiently and cause premature piston failure.

Inspect bits: Dull bits will slow down drilling speed and overstrain the drill mechanism. When changing bits be sure new bit is of the correct gauge to follow the previous bore.

Be sure compressor delivers between 80 and 90 psi air pressure at the tool. High pressure will cause rough operation and excessive breakage. Low pressure results in slow drilling speed.

Always hold the drill down to its work with the machine in line with the drill steel to ease the rotational load.

Frequently blow rock cuttings out of dry holes by lifting the blower valve (18) on the top of the tool.

Never continue to drill with a plugged drill steel.

Maintenance

A drill in constant use should be dismantled, cleaned and inspected at least weekly. Worn parts should be replaced to maintain drilling efficiency and avoid high upkeep costs.

Check the condition of the chuck, worn, bell mouthed chucks hold the steel out of line which spalls or fractures the striking end of the piston.

The splines of the rotation parts, rifle bars, rifle bar nuts and chuck rotation nuts, should be inspected for excessive wear. Too much play in the parts results in lost rotational force. Worn pawls, worn ratchet rings and broken or weak pawl springs should be replaced.

Reface spalled or cupped pistons to avoid uneven force on drill steel and eventual fracture of the piston.

With adequate lubrication the cylinder bushing is a long lived part. If worn, however, it should be replaced to preserve the front cushion and avoid breakage of piston and fronthead parts.

Be sure that valve parts work freely and are clean and free from grit. Be careful in disassembling and assembling valve to avoid burring or scoring faces.

When assembling tool, draw up thru bolts evenly and tightly. Rotate chuck by hand to make sure that chuck does not bind in fronthead.

SPARE PARTS SERVICE CHART

Index No.	CP Part No.	Description	No. Req'd.	High Wear 100%	Med. Wear 70%	Low Wear 30%	Non-Wear 10%	Subject To External Damage
1	R086608	Bracket-Handle	1			X		
2	R076173	Bolt-Handle	1			X		
3	R075419	Grip-Handle	2		X			
4	R000142	Washer-Handle Bolt Key	1				L	
5	R076172	Liner-Handle	1				X	
6	R110317	"O" Ring	1	X				
9	R005584	Screen-Air Inlet	1					D
11	R075265	Swivel-Air Inlet	1			X		
12	R000530	Nut-Air Inlet Swivel	1			X		
13	P103521	"O" Ring	1	X				
14	R076266	Pin-Spring	1			L		
15	R075780	Washer-Valve Spring	1			L		
18	R075778	Spring-Blower Valve	1		L			
17	R075777	Washer-Blower Valve	1			X		
18	R086612	Valve-Blower	1			X		
20	R086623	Bolt-Thru	2			X		
21	R085756	Nut-Thru Bolt	2			X		
22	*	Fronthead	1			X		
25	*	Retainer	1			X		
26	R093896	Trunnion-Retainer	2		X			
27	R005742	Nut-Elastic Stop	3			R2		
29	R087990	Cylinder	1		X			
30	R087948	Backhead	1			X		
31	C068064	Plug-Pipe	2				X	
32	R079124	Handle-Throttle Valve	1					X
33	C036717	Lockwasher-Valve Handle	1		L			
34	P002149	Nut-Hex	1			X		
36	R075449	Washer-Air Tube	1				L	
37	R075099	Rubber-Air Tube	1		X			
38	R076194	Ring-Ratchet	1		X			
39	R076264	Case-Valve	1			X		
40	R086611	Bushing-Blower Valve	1			X		
42	*	Nut-Rifle Bar	1		X			
43	R000088	Piston	1		X			
44	R085611	Plug-Oil	1					X
45	R091176	Gasket-Oil Plug	1			L		
47	R042161	Bushing-Cylinder	1		X			
50	*	Tube-Air (Tube-Water)	1			D		
51	R086733	Nut-Chuck Rotation	1		X			
52	*	Sleeve-Chuck	1			X		
53	R093898	Retainer-Shoe Latch	1		X			
54	R093897	Buffer-Retainer	1		X			
56	*	Chuck	1		X			
57	R086622	Bar-Rifle	1		X			
58	R076263	Valve	1		X			
61	R085625	Stem-Oil Regulating	1			L		
62	R098084	Plug-Oil Regulating	1			L		
63	R098085	Bushing-Valve Guide	1		X			
64	C068799	Plug-Pipe	1				X	
65	R076793	Plug-Air Tube	1				X	
66	R000537	Gasket-Tube Plug	2		L			
68	C079489	"O" Ring	1		X			
69	R098054	Bushing-Water Valve	1			X		
71	R079130	Plug-Water Valve Port	1				X	
72	R076372	Plug-Water Connection	1			X		
74	R085671	Spring-Valve Plunger	1		L			
75	R075802	Pin-Valve Plunger	1			L		
76	R086627	Plunger-Throttle Valve	1		L			
77	R086628	Valve-Throttle	1			X		
79	R075772	Pin-Valve Case Dowel	1			L		
80	R075627	Pawl	4	X				
81	R086654	Spring-Pawl	4	X				
96	R124145	Cap-Filler	1					X
97	C068799	Plug-Pipe	1					X
98	R124143	Hood-Muffler (Right)	1		X			
99	R124144	Hood-Muffler (Left)	1		X			
100	R117415	Screw	8			X		

THIS SERVICE CHART IS PUBLISHED AS A GUIDE TO EXPECTANT LIFE OF COMPONENT PARTS. THE REPLACEMENT LEVELS ARE BASED ON AVERAGE TOOL USAGE OVER A ONE YEAR PERIOD.

EXAMPLE: For 10 tools in use: 10 high wear items will be required per year, 7 medium wear items, etc.

NOTE: Quantities must be increased where tool is subjected to more severe and/or continuous usage.

LEGEND

- X—Type of wear, if no other comments apply.
- L—Easily lost. Carefully reserve during disassembly.
- D—Easily damaged during disassembly and assembly.
- R2—Replace each second time tool is disassembled.

* See Part Lists



**Chicago
Pneumatic™**

Chicago Pneumatic Construction Tools
SE-105 23, Stockholm, Sweden.
www.chicagopneumatic.com